

- 1. POST TO WITHSTAND 13 NEWTONS (3LBS.) MIN. AXIAL FORCE IN BOTH DIRECTIONS SHOWN WITHOUT DISLODGING.
- 2. TOLERANCES APPLY TO SOLDER SIDE OF BOARD.
- 3. MEASURED AT SURFACE -C-
- 4. PLASTIC FLASH PERMITTED IN THIS AREA.
- 5. PARTS COMPLY WITH AMP SOLDERABILITY SPEC. NO. 109-11-2.
- 6. ONE HOLE MAY BE UNDERSIZED (.065/.060 DIA.) FOR ASSEMBLY RETENTION DURING WAVE SOLDERING.
- 7. MATERIAL: HEADER-THERMOPLASTIC POLYESTER NON-FILLED 94V-0(NATURAL) POST-COPPER ALLOY (SEE NOTES 13 & 14 FOR PLATING)
- 8. COORDINATE DIMENSION APPLIES FROM CENTER OF ACTUAL FEATURE.
- 9. PLASTIC BURRS CAUSED BY CUT-OFF TOOLING ARE PERMITTED WITHIN THE MAXIMUM TOLERANCE ENVELOPE.
- 10. POST TO BE MEASURED WHEN STRIP IS HELD FLAT.
- 11. POST MUST WITHSTAND TWO 90° BENDS AGAINST EXTRUSION WITHOUT BREAKING.
- 12. DIMENSION SHOULD BE .140-.430 WHEN MATING WITH A MTA 156 CONNECTOR ASSEMBLY, .140 MIN WHEN MATING WITH A SL 156 WIRE-TO-BOARD CONNECTOR ASSEMBLY OR .140-.475 WHEN MATING WITH A SL 156 BOARD-TO-BOARD CONNECTOR ASSEMBLY.
- 13. GOLD PLATE AREA, .000015 MIN., ALL SIDES, OVER NICKEL UNDERPLATE, .000050 MIN., ALL SIDES AND ENTIRE LENGTH OF POST.
- 14. BRIGHT TIN/LEAD (93/7) PLATE AREA, .000150-.000350 THICK, ALL FOUR SIDES, .175 MIN. FOR -2 THRU -24. MATTE TIN PLATE AREA .000150-.000350 THICK ALL FOUR SIDES, .175 MIN FOR -32 THRU -54

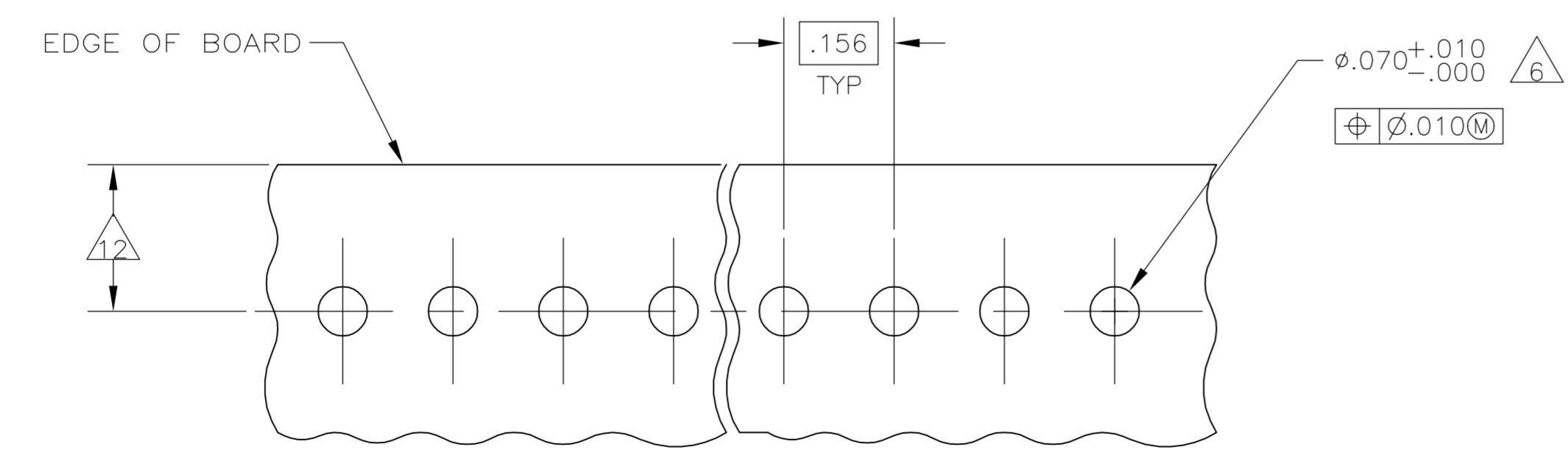
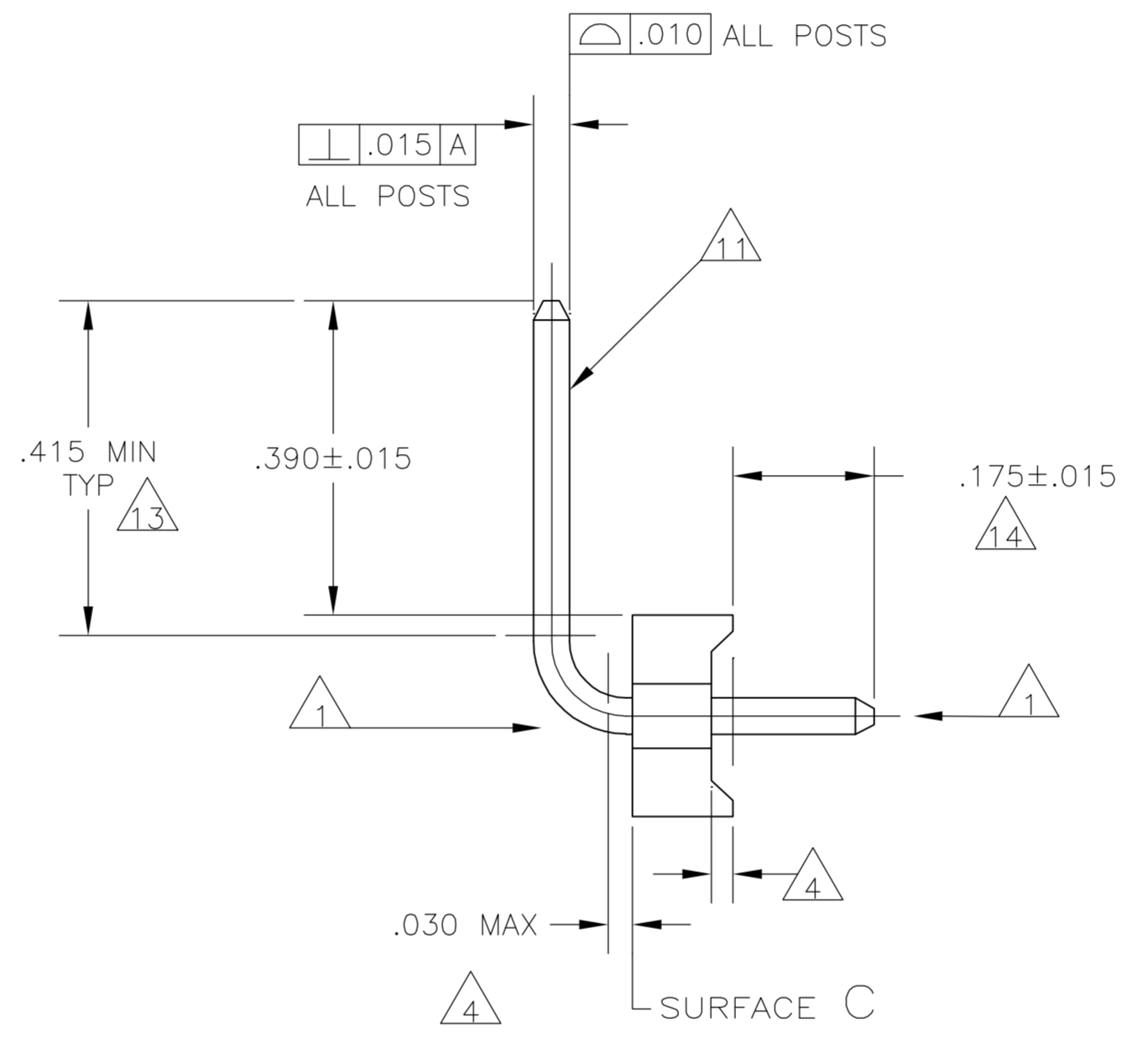
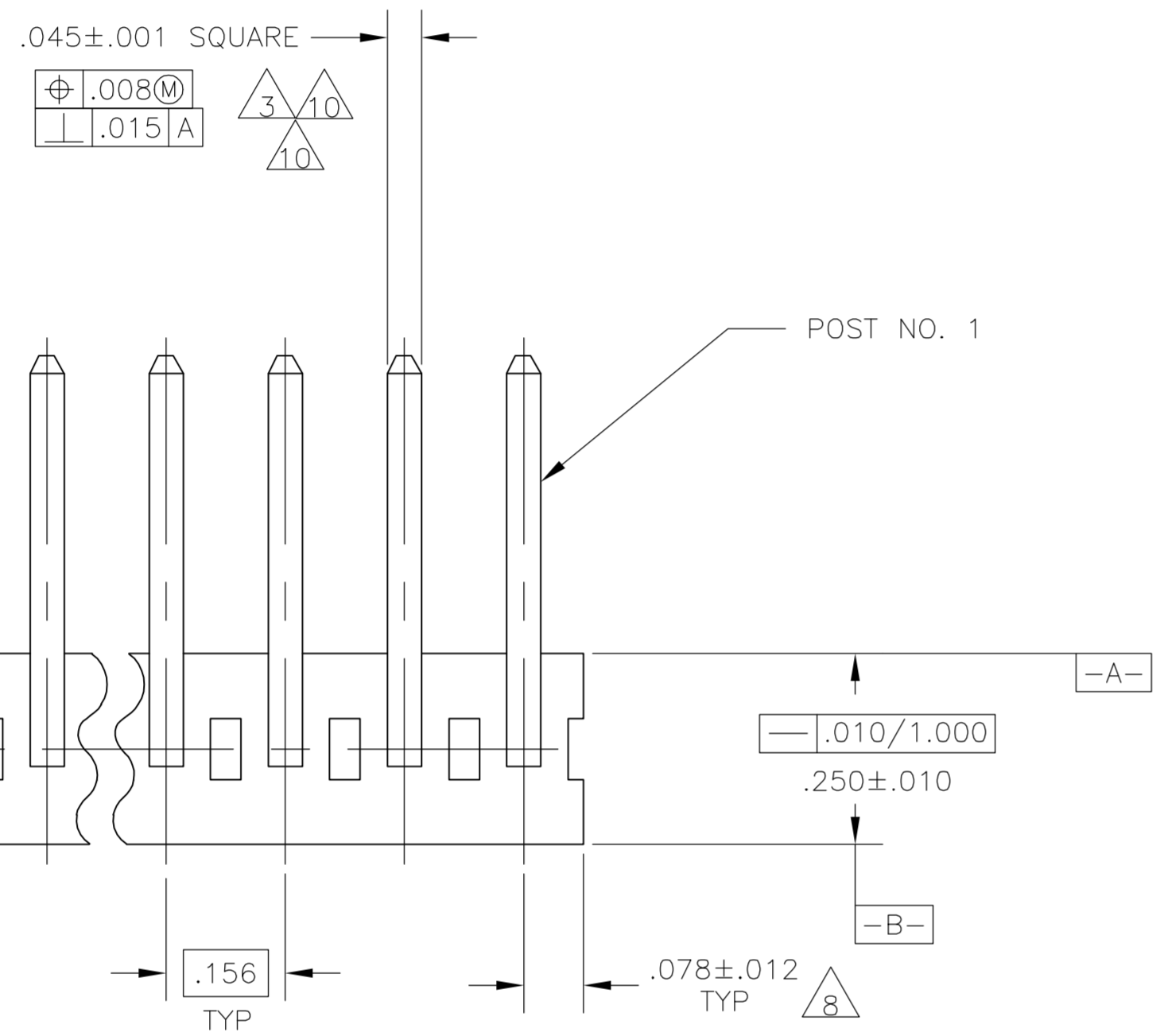

RECOMMENDED MOUNTING HOLE PATTERN FOR .063 THICK P.C. BOARD

.012	0.30	.100	2.54	1.000	25.40
.010	0.25	.078	1.98	.475	12.07
.008	0.20	.070	1.78	.430	10.92
.005	0.13	.065	1.65	.415	10.54
.001	0.03	.063	1.60	.390	9.91
.000350	0.00889	.060	1.52	.250	6.35
.000150	0.00381	.045	1.14	.175	4.45
.000050	0.00127	.030	0.76	.156	3.96
.000030	0.00076	.018	0.46	.140	3.56
.000	0.00	.015	0.38	.125	3.18
IN	MM	IN	MM	IN	MM

FINISH	IN	MM	NUMBER OF POSITIONS	PART NUMBER	FINISH	IN	MM	NUMBER OF POSITIONS	PART NUMBER
TIN	3.744	95.10	24	5-644758-4	TIN-LEAD	3.744	95.10	24	2-644758-4
TIN	3.588	91.14	23	5-644758-3	TIN-LEAD	3.588	91.14	23	2-644758-3
TIN	3.432	87.17	22	5-644758-2	TIN-LEAD	3.432	87.17	22	2-644758-2
TIN	3.276	83.21	21	5-644758-1	TIN-LEAD	3.276	83.21	21	2-644758-1
TIN	3.120	79.25	20	5-644758-0	TIN-LEAD	3.120	79.25	20	2-644758-0
TIN	2.964	75.29	19	4-644758-9	TIN-LEAD	2.964	75.29	19	1-644758-9
TIN	2.808	71.32	18	4-644758-8	TIN-LEAD	2.808	71.32	18	1-644758-8
TIN	2.652	67.36	17	4-644758-7	TIN-LEAD	2.652	67.36	17	1-644758-7
TIN	2.496	63.40	16	4-644758-6	TIN-LEAD	2.496	63.40	16	1-644758-6
TIN	2.340	59.44	15	4-644758-5	TIN-LEAD	2.340	59.44	15	1-644758-5
TIN	2.184	55.47	14	4-644758-4	TIN-LEAD	2.184	55.47	14	1-644758-4
TIN	2.028	51.51	13	4-644758-3	TIN-LEAD	2.028	51.51	13	1-644758-3
TIN	1.872	47.55	12	4-644758-2	TIN-LEAD	1.872	47.55	12	1-644758-2
TIN	1.716	43.59	11	4-644758-1	TIN-LEAD	1.716	43.59	11	1-644758-1
TIN	1.560	39.62	10	4-644758-0	TIN-LEAD	1.560	39.62	10	1-644758-0
TIN	1.404	35.66	9	3-644758-9	TIN-LEAD	1.404	35.66	9	644758-9
TIN	1.248	31.70	8	3-644758-8	TIN-LEAD	1.248	31.70	8	644758-8
TIN	1.092	27.74	7	3-644758-7	TIN-LEAD	1.092	27.74	7	644758-7
TIN	.936	23.77	6	3-644758-6	TIN-LEAD	.936	23.77	6	644758-6
TIN	.780	19.81	5	3-644758-5	TIN-LEAD	.780	19.81	5	644758-5
TIN	.624	15.85	4	3-644758-4	TIN-LEAD	.624	15.85	4	644758-4
TIN	.468	11.89	3	3-644758-3	TIN-LEAD	.468	11.89	3	644758-3
TIN	.312	7.92	2	3-644758-2	TIN-LEAD	.312	7.92	2	644758-2

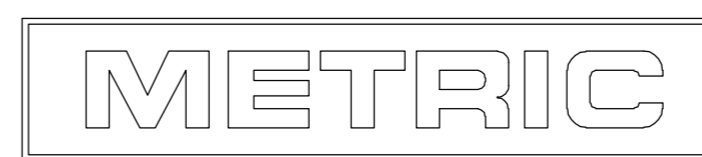

THIS DRAWING IS A CONTROLLED DOCUMENT.

DIMENSIONS: INCHES	TOLERANCES UNLESS OTHERWISE SPECIFIED:	0 PLC ± -	1 PLC ± -	2 PLC ± -	3 PLC ± .005	4 PLC ± -	ANGLES ± -
--------------------	--	-----------	-----------	-----------	--------------	-----------	------------

APPROVED: R. SWING, D. CLARK, NAME: MTA-156 HEADER ASSEMBLY, PLAIN, RIGHT ANGLE, .045 SQUARE POST, .000030 GOLD, SPECIAL.

SIZE: A1, CASE CODE: 00779, DRAWING NO: 644758, RESTRICTED TO: CUSTOMER DRAWING, SCALE: 5:1, SHEET: 1 OF 1, REV: A